

LRI – LAL (CNRS, UP-11)  
LIMSI (CNRS, UP-6 ET 11)  
St Anne Tenon FMP

AlGorille (INRIA, CNRS, INPL)  
CRAN (CNRS, INPL, UHP)

LPC (CNRS, IN2P3,  
UBP)

CHRU Clermont-Ferrand

CREATIS  
(CNRS, INSERM,  
INSA, UCBL)

Rainbow (CNRS, I3S, UNSA)  
Epidaure (INRIA-Sophia)  
Centre Antoine Lacassagne

14 chercheurs informatique  
6 médecins  
6 thésards  
4 ingénieurs  
10 temps pleins

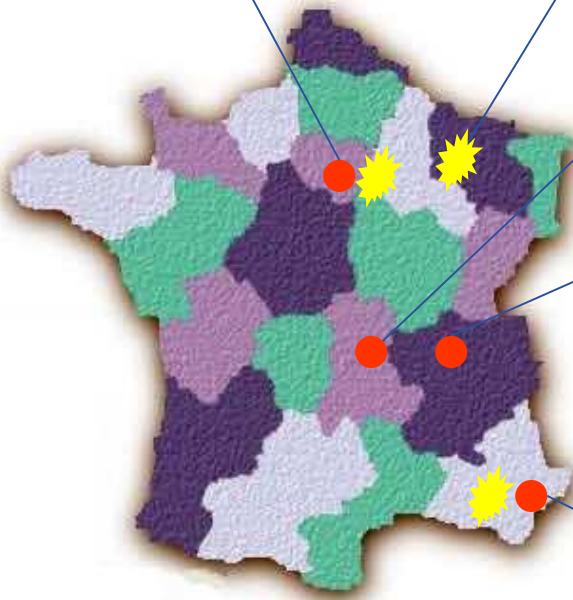

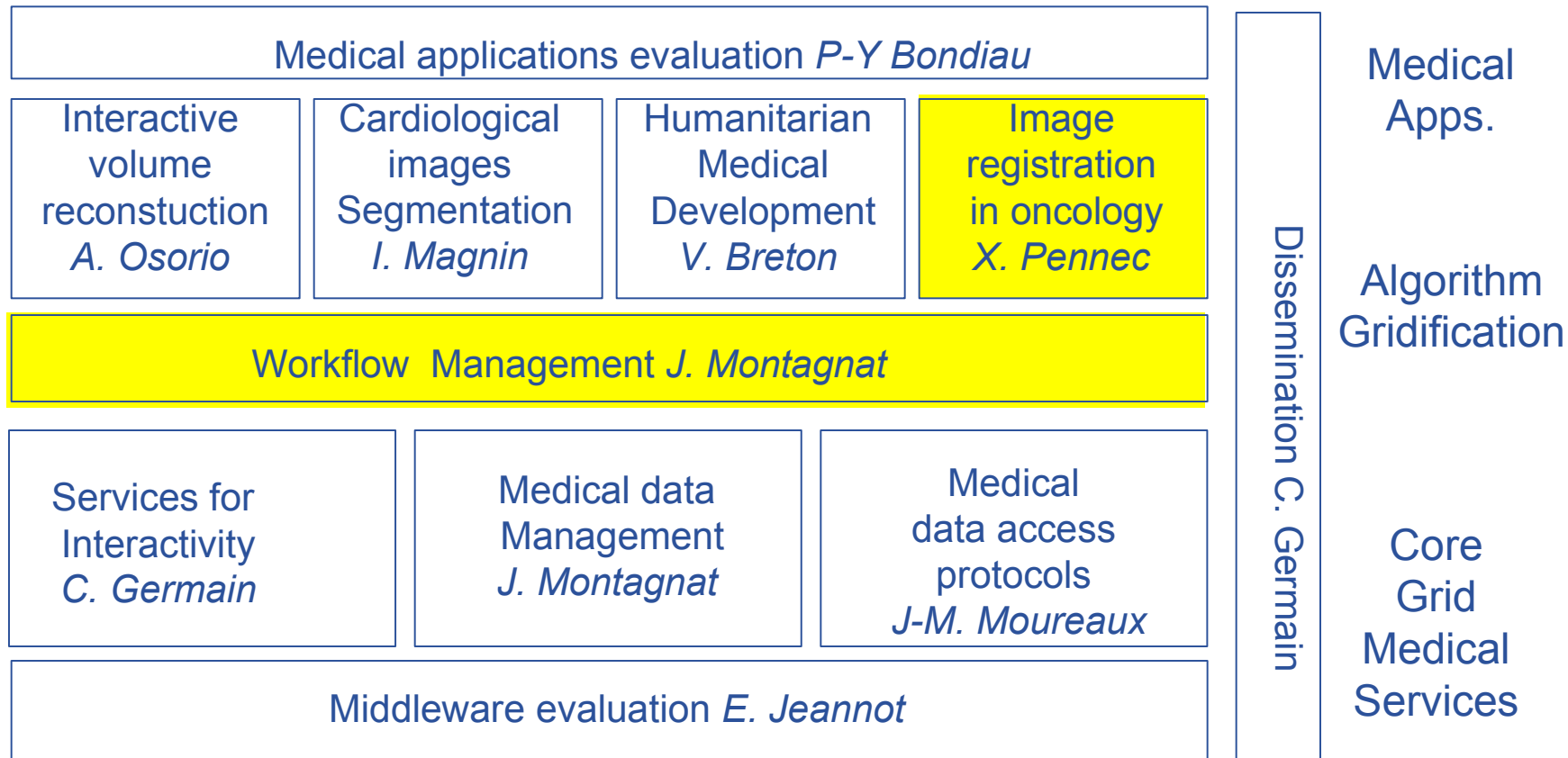

# AGIR

Analuse Globalisée des Données d'Imagerie Radiologique

## From Image Registration in Oncology to Complex Workflows on the GRID

Xavier Pennec, PhD, INRIA-Sophia, projet Epidaure

**Johan Montagnat, PhD, I3S, Rainbow team**

Tristan Glatard, I3S, Rainbow + INRIA, Epidaure teams

Pierre-Yves Bondiau, MD, PhD, Centre Antoine Lacassagne, Nice

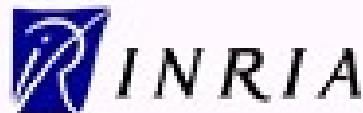

- **The Medical application:**
  - Registration for oncology
- **The scientific question:**
  - Evaluation / comparison of registration algorithm performances
- **The technical challenge:**
  - Running the workflow on the GRID



- **Registration / segmentation are basic components of medical image analysis**
  - Registration: finding homologous points / transformation
  - Segmentation: give anatomical label to each image point
- **Registration for brain radiotherapy**
  - Planning
    - Fusion of image modalities (multimodal, rigid)
    - Warp atlas to patient image for segmentation (mono-modal, non-rigid)
    - Definition of Target volumes and Organs at risk: dose optimization
  - Follow-up (monomodal rigid)

The logo for HEALTHGRID features the word "HEALTHGRID" in a green, sans-serif font. The letter "H" is stylized with a red vertical line extending upwards from its top bar. The letter "I" is replaced by a red vertical line with a small red dot above it, resembling a medical cross or a specific anatomical marker. The entire logo is underlined with a red line.

[http://www.healthgrid.org/docs/pdf/WhitePaperdraft\\_v1.1-3reviewedv2.pdf](http://www.healthgrid.org/docs/pdf/WhitePaperdraft_v1.1-3reviewedv2.pdf)  
(ch 3/4)

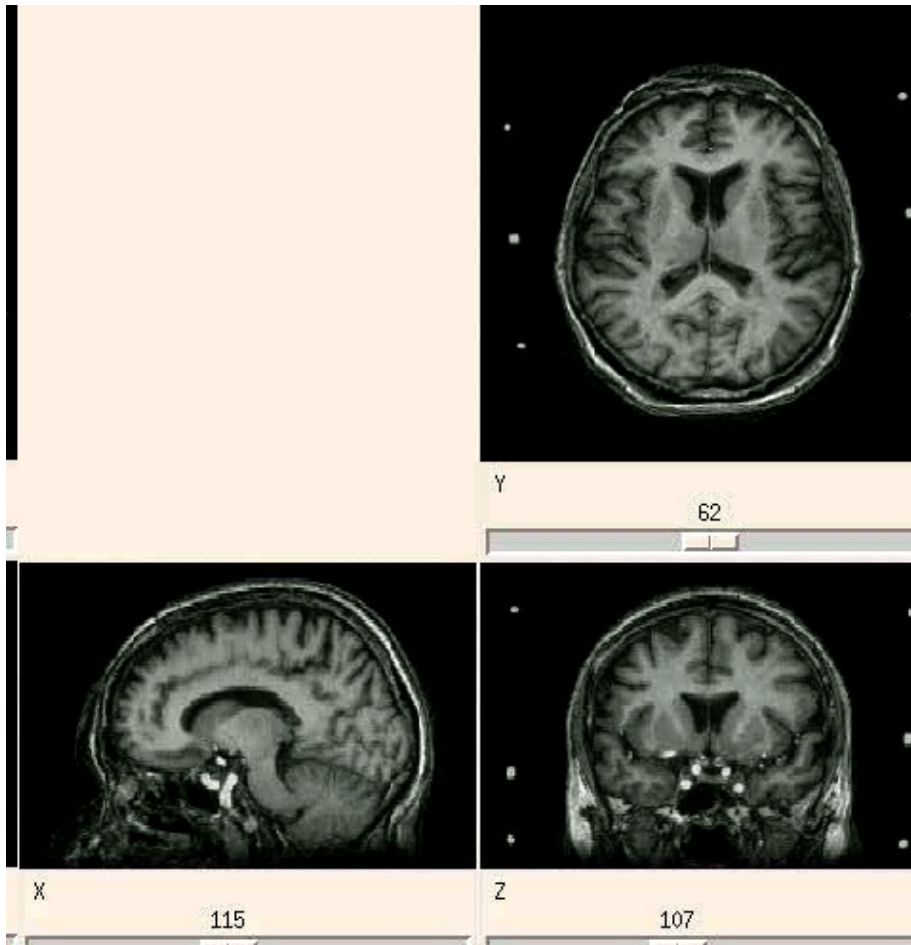

## Inter-subject registration Affine transformation

MR T1 Images

256x256x120 voxels

Atlas to patient registration  
for radiotherapy planning

Correct size and position but high remaining variability in cortex and deep structures

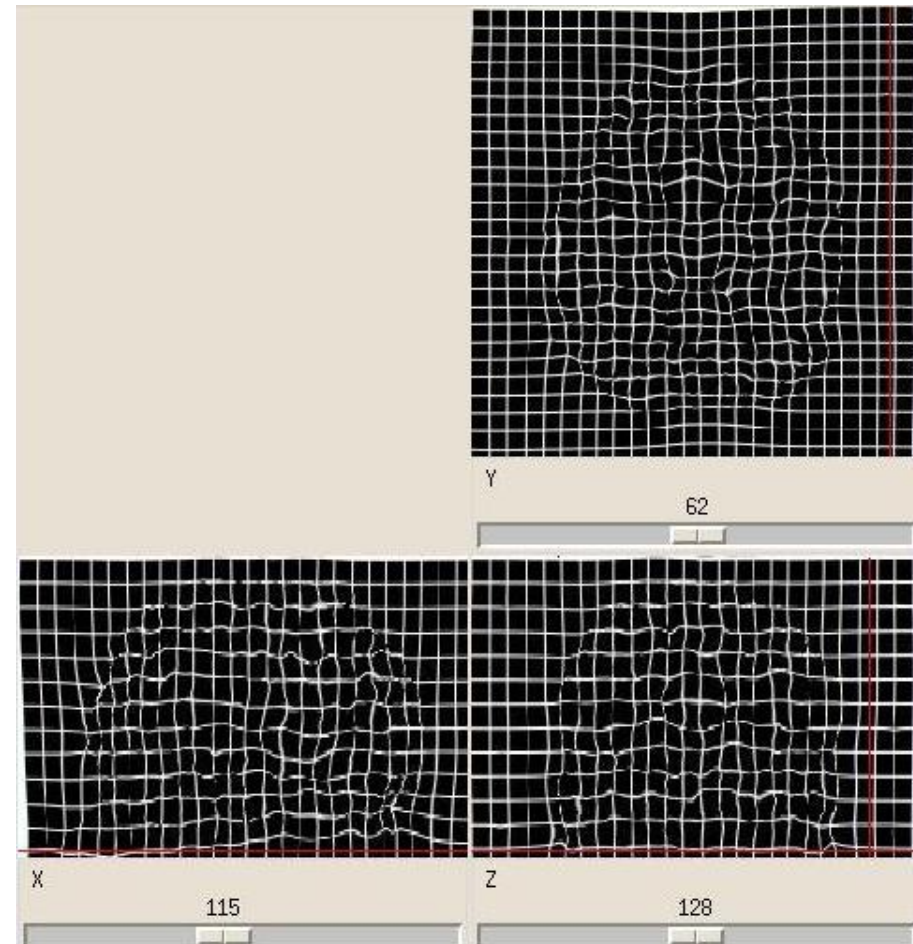
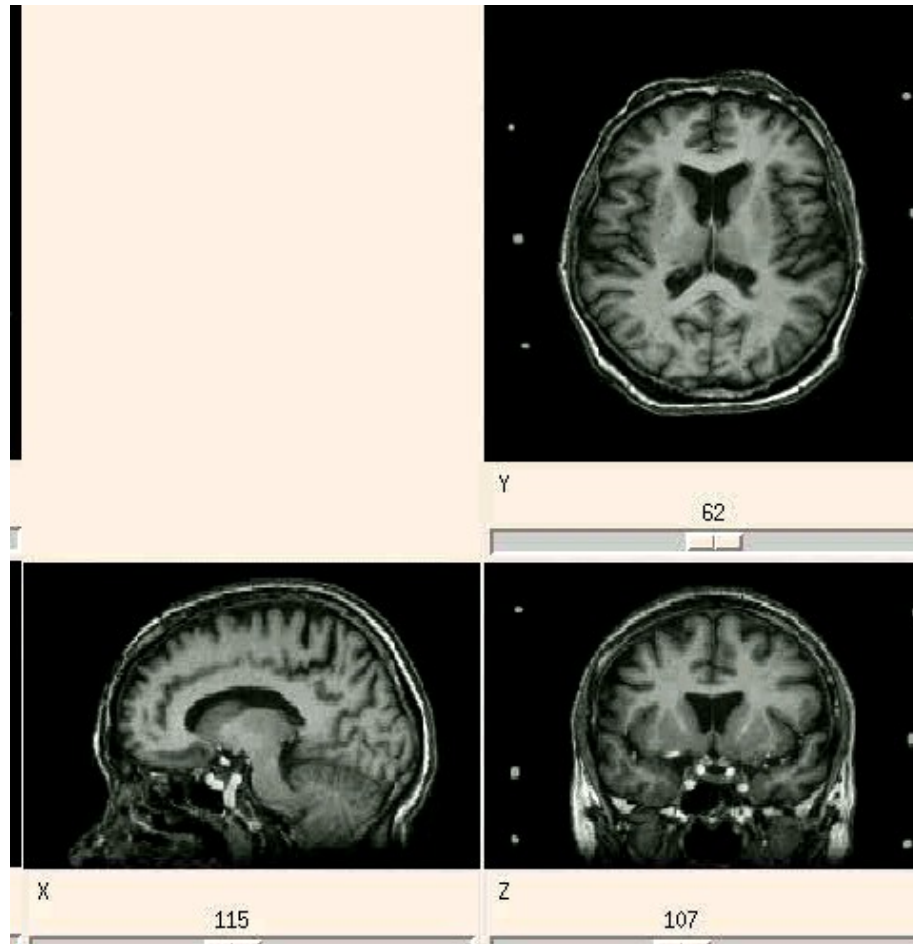

Registration in 5 min on 15 PCs

Anatomically meaningful deformation

**Adaptive non-stationary visco-elastic inter-subject registration**

## Propagate the segmentation of structure of interest from the atlas to the patient image

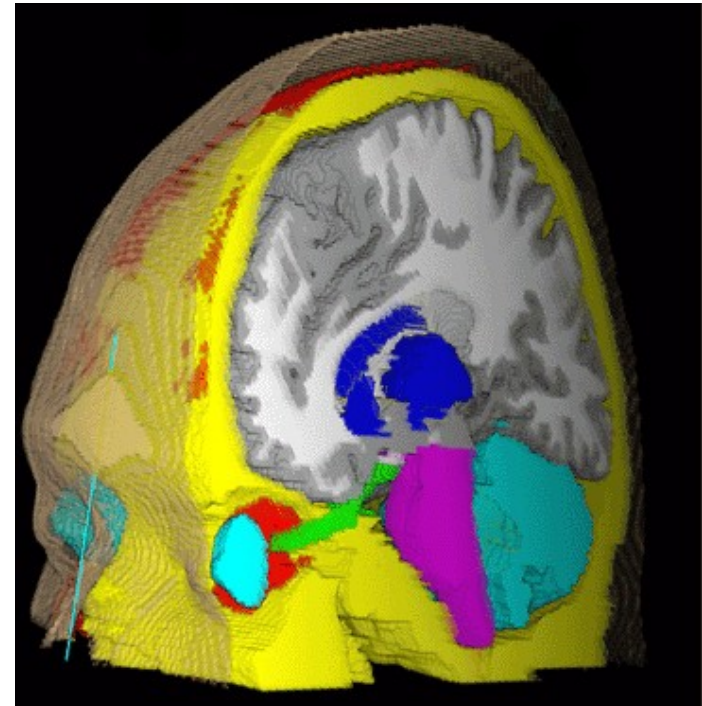
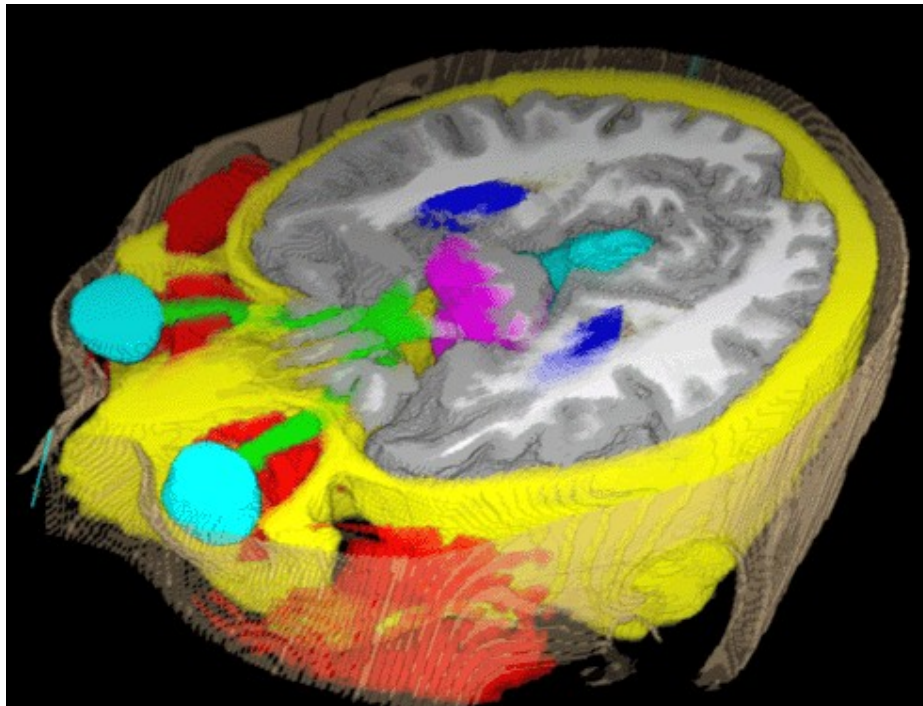



- Define target volume and organs at risk thanks to the segmentation
- Optimize the irradiation process to
  - maximize the dose within the tumor
  - minimize it within neighboring organs at risk

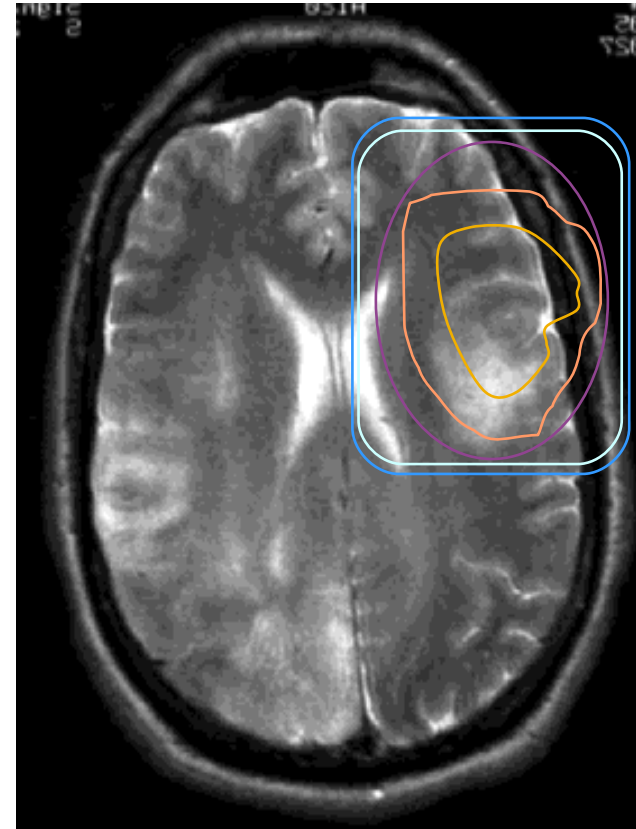
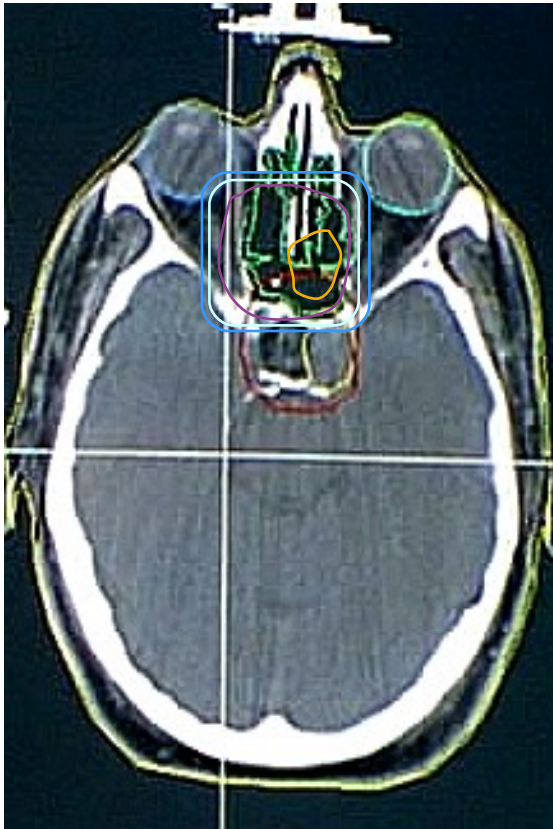

- **There is no universal registration algorithm**
  - More than 600 references on medical image registration in 1997
  - More than 100 papers each year... (70 at MICCAI 2004 only)
- **Registration algorithms as Grid services**
  - Use up to date algorithm
  - **Evaluation / comparison of algorithm performances**
- **Challenges**
  - Inter-operability (coordinate systems, transformation format...)
  - Ontology describing data, registration problems and algorithms

- **The Medical application:**
  - Registration for oncology
- **The scientific question:**
  - Evaluation / comparison of registration algorithm performances
- **The technical challenge:**
  - Running the workflow on the GRID

## Fixed internal parameters

- Multiscale resolution
- (Typical variance...)

## Varying internal parameters

- Initial transformation
- (...)

## External parameters

- Data (image) 1
- Data (image) 2
- Acquisition noise
- Patient effects

Registration algorithm

```
graph TD; subgraph External; E1[Data (image) 1]; E2[Data (image) 2]; E3[Acquisition noise]; E4[Patient effects]; end; subgraph Fixed; F1[Multiscale resolution]; F2["(Typical variance...)"]; end; subgraph Varying; V1[Initial transformation]; V2["(...)"]; end; RA[Registration algorithm]; E1 --> RA; E2 --> RA; E3 --> RA; E4 --> RA; F1 --> RA; F2 --> RA; V1 --> RA; V2 --> RA; RA --> FT[Final transformation];
```

## Final transformation

- **Robustness:** ability to find the right transformation (success/failure)
- **Repeatability:** w.r.t. some parameters (e.g. initialization)
- **Accuracy:** Variability w.r.t. the ground truth for typical data

- **Robustness:**
  - size of the basin of attraction
  - Probability of convergence

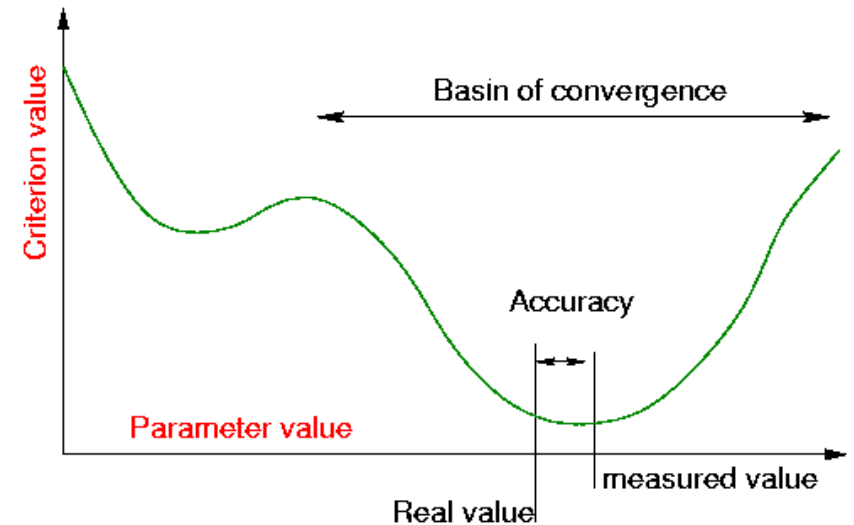

- **Uncertainty = deviation from the real transformation**
  - Mean Error: covariance matrix, std dev.
  - On the transformation ( rotation  $\sigma_r$  [rad], translation  $\sigma_t$  [mm])
  - On test points (TRE  $\sigma_x$ )

- **Synthetic data (simulation):**
  - Available ground truth
  - Difficult to identify and model all sources of variability
- **Real data in a controlled environment (Phantom):**
  - Possible gold standard
  - Performances evaluation in specific conditions
    - Difficult to test all clinical conditions
    - May hide a bias
- **Image database representative of the clinical application**
  - Usually no ground truth
  - Should span all sources of variability

- **Bronze standard: The exact result is an unknown variable**
  - Unbiased estimation: use redundant information
    - use many different registration algorithms (average biases, so that precision  $\sim$  accuracy)
    - Use many different data (redundant information to ensure precision)
    - Average transformations (maximal consistency)

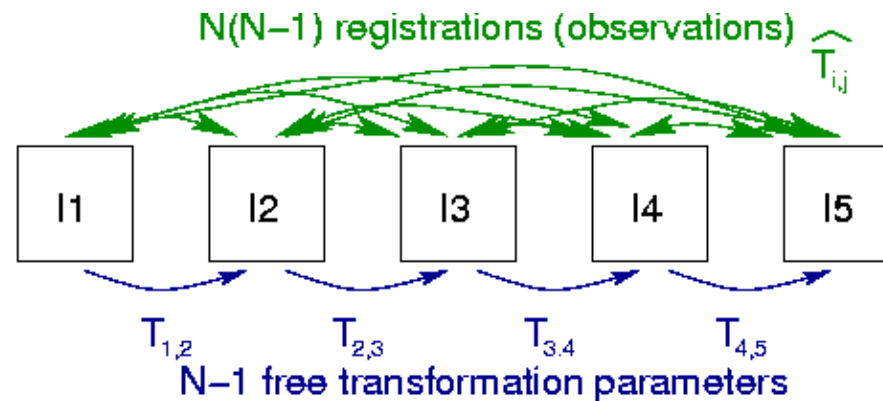

- **Best explanation of the observations (ML) :**
  - Robust Fréchet mean
  - Robust initialisation and Newton gradient descent

$$d^2(T_1, T_2) = \min(\mu^2(T_i, T), \chi^2)$$

- **Result**  $T_{i,j}, \sigma_{rot}, \sigma_{trans}$

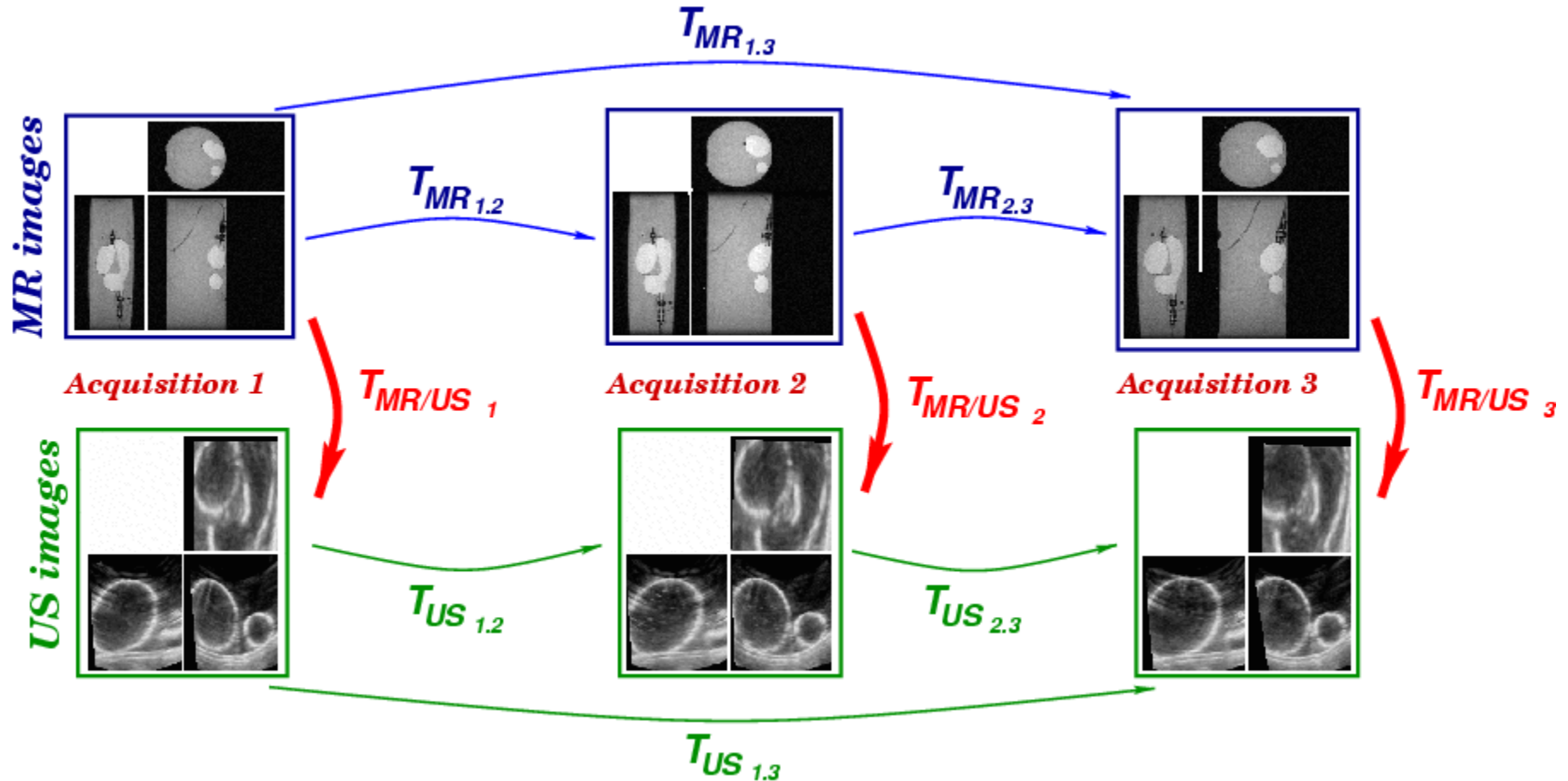

$$\sigma_{loop}^2 = 2\sigma_{MR/US}^2 + \sigma_{MR}^2 + \sigma_{US}^2$$



- **Data intensive application:**
  - High number of images across different databases
  - High number of registration algorithms
  
- **Grid validation protocol (PhD Tristan Glatard)**
  - Find available data that match the problem description
  - Find the algorithms that can deal with them
  - Find and organize the resources to do the job

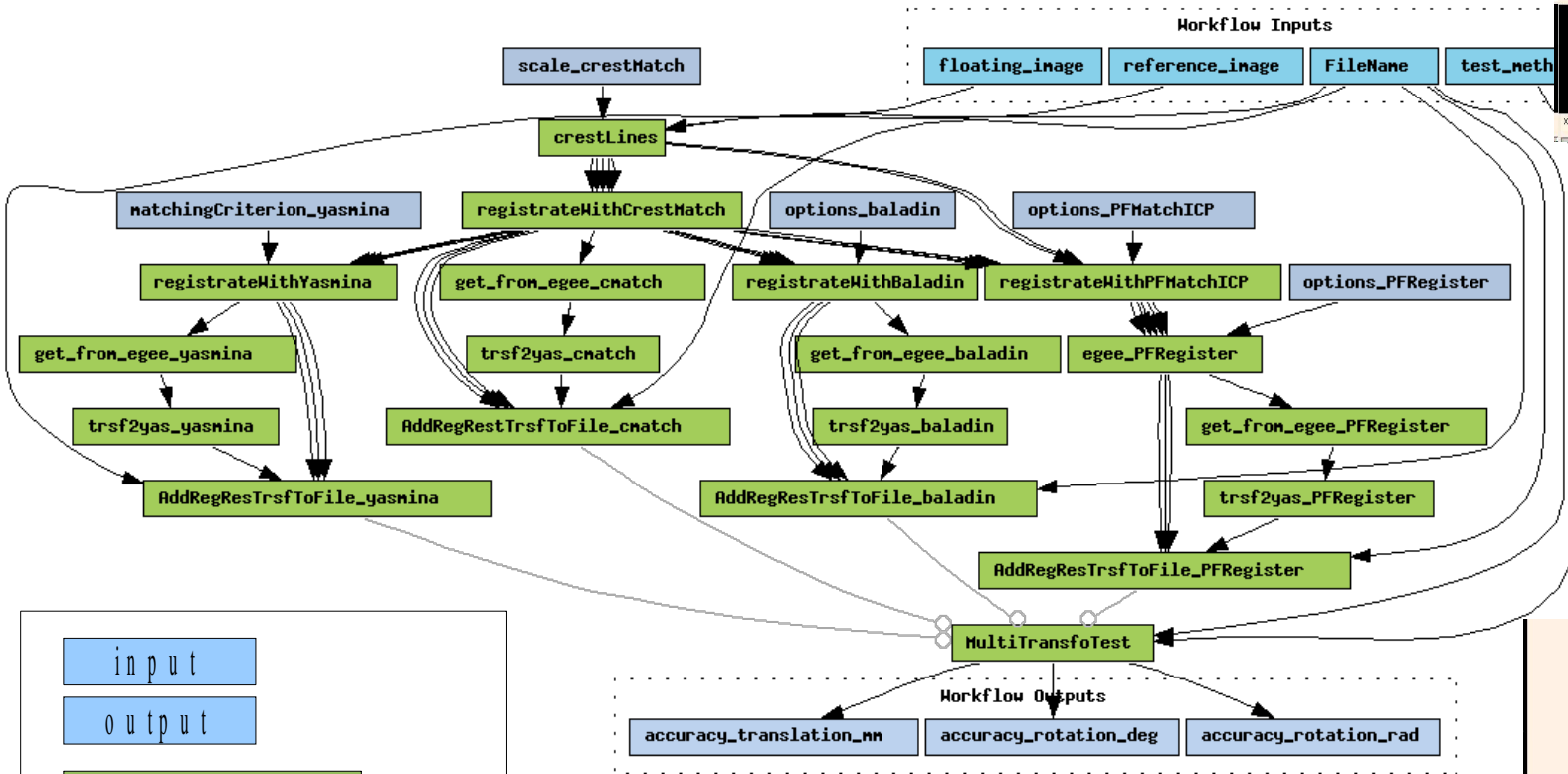

input

output

Web Service

→ Data link

○ Control link

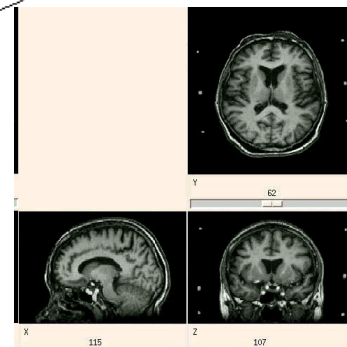

- **The Medical application:**
  - Registration for oncology
- **The scientific question:**
  - Evaluation / comparison of registration algorithm performances
- **The technical challenge:**
  - Running the workflow on the GRID



- **Workflow description**

- Business workflows (e.g. BPEL)
  - Control-centric
- Scientific workflows (e.g. Scuffl)
  - Data-centric

- **Workflow execution**

- Task-based workflows (e.g. DAGMan)
  - Explicit mention of data dependencies
  - Complex workflow, simple optimisation ← **CS friendly**
- Service-base workflows (e.g. Taverna)
  - Independent expression of processors and input data-sets
  - Simple workflows, complex optimisation ← **user friendly**

- **Chosen workflow management tool: Taverna**
  - Developed in the UK eScience myGrid project (bioinformatique)
  - Open source : <http://taverna.sourceforge.net>
  - Based on web-services
  - Most powerful workflow manager for description

- **Exploiting workflow parallelism**

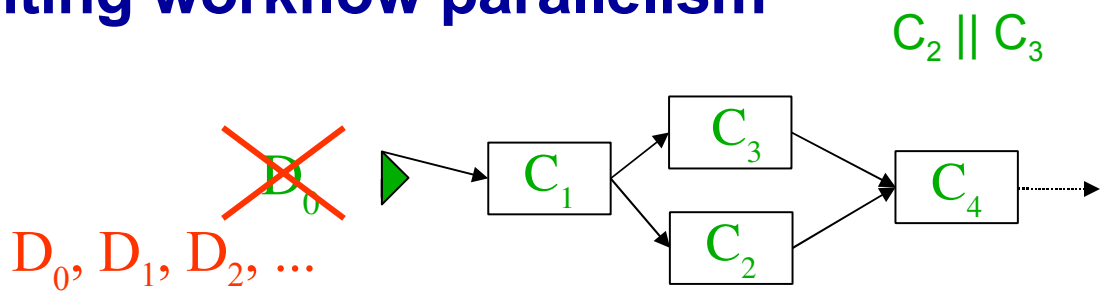

- **Grid interface (Grid 5000 / EGEE)**

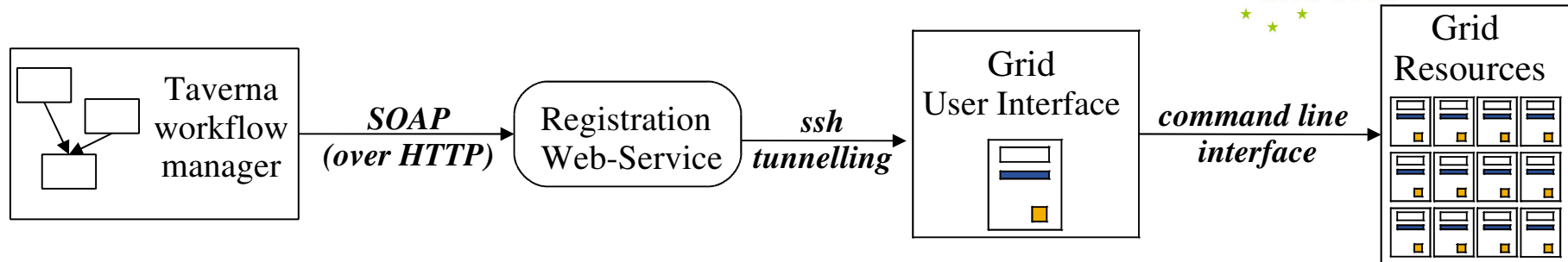

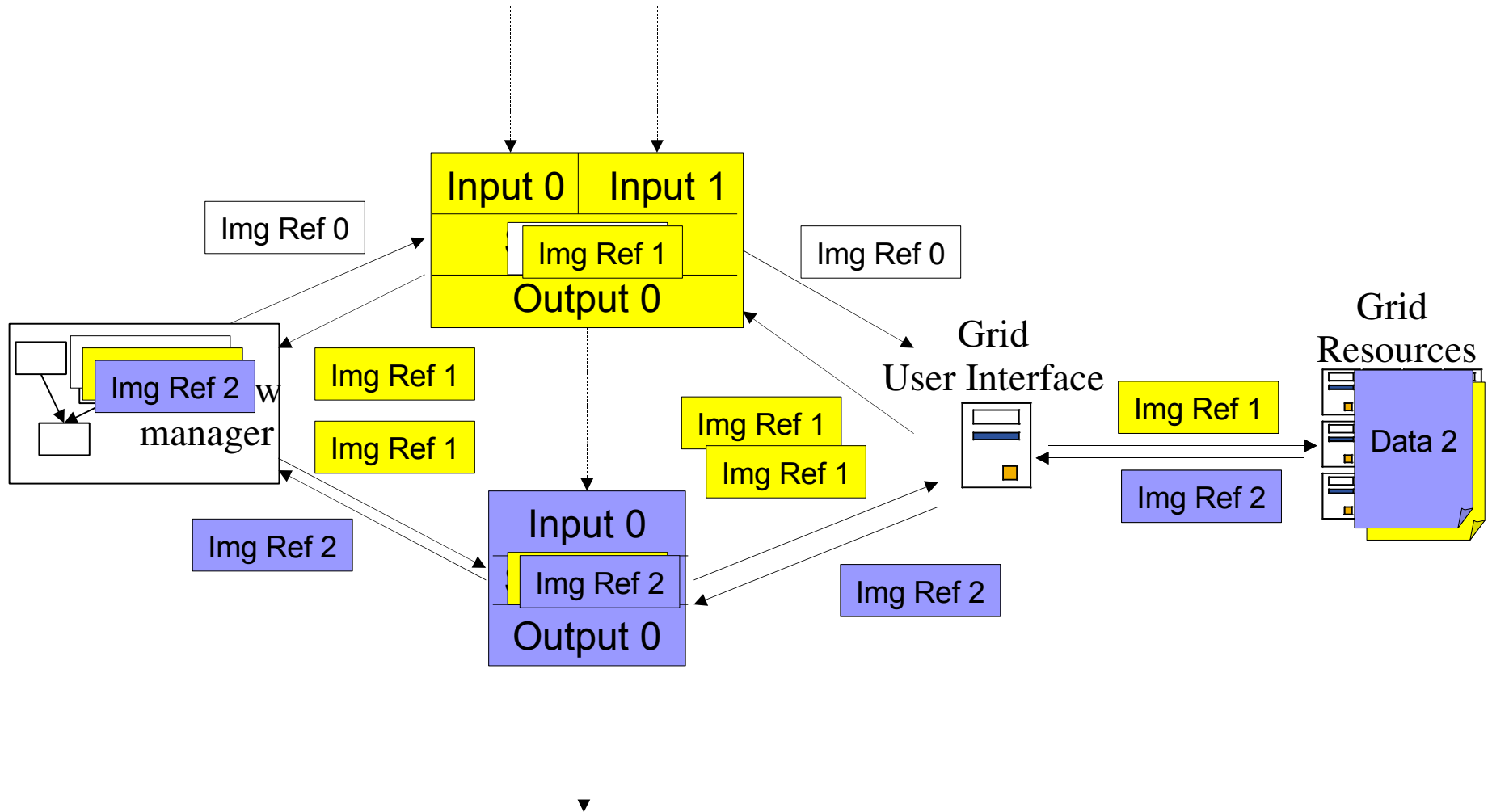

- Data
  - « **Masses de données** »
- Services
  - **Standard (Web-Services)**
  - **Independent (legacy code, services developed independently)**
- Execution engine
  - **Isolated from the grid**
- Grid
  - **Batch-oriented system**
  - **No global workflow view**
  - **Not even WS view**

- **Data parallelism:**

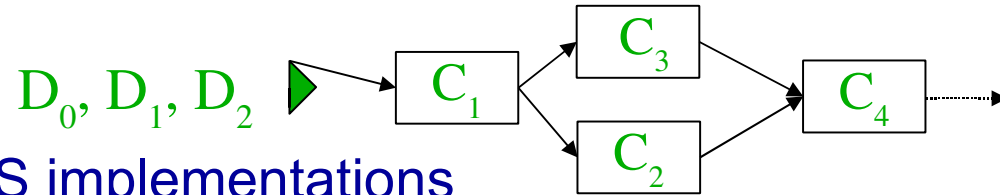

- Lack of asynchronous WS implementations
- Patch with submission/fetching services
  - Data order is not preserved (send 1/2/3, receive 3/1/2)
  - Need a track record for each result

- Synchronous interaction

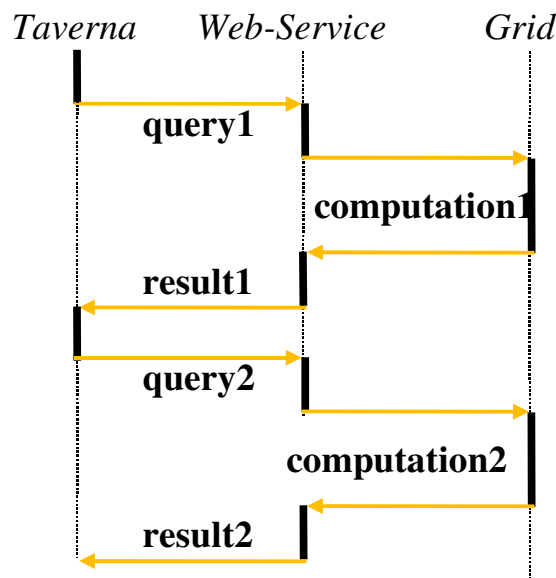

- Asynchronous interaction

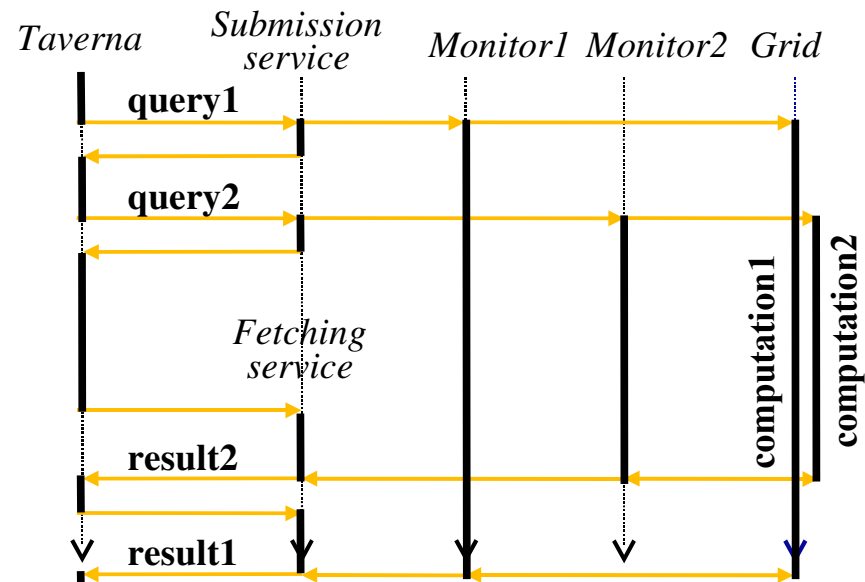



- Data + component parallelism: streaming (Pipelining)**

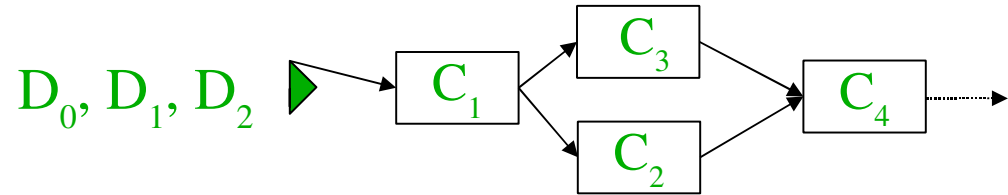

$C_1$	$D_0$	$D_1$	$D_2$	-	-	-	-
$C_2$	-	-	-	$C_1 * D_0$	$C_1 * D_1$	$C_1 * D_2$	-
$C_3$	-	-	-	$C_1 * D_0$	$C_1 * D_1$	$C_1 * D_2$	-
$C_4$	-	-	-	-	-	-	Mean

$C_1$	$D_0$	$D_1$	$D_2$	-	-
$C_2$	-	$C_1 * D_0$	$C_1 * D_1$	$C_1 * D_2$	-
$C_3$	-	$C_1 * D_0$	$C_1 * D_1$	$C_1 * D_2$	-
$C_4$	-	-	-	-	Mean

- $N_w$  sequential steps,  $N_D$  Data sets, Mean time  $T$  per component
- Execution time =  $N_D \cdot N_w \cdot T$  vs  $(N_D + N_w - 1) \cdot T$
- Example for registration:
  - $n_D = 50$  ;  $n_w = 4$  ;  $T = 30\text{min}$
  - Execution time = 100h vs 26.5 h

- Data intensive applications**

- **Development of a new execution engine : MOTEUR**
  - compatible with Taverna description (Scufl)
  - Allowing data and component parallelism
  - Implementing result traceability

<http://www.i3s.unice.fr/~glatard>

- **Execution infrastructures**



> 1000 procs

OAR batch submitter  
research infrastructure



> 16000 procs, 5 PB

LCG2 middleware (migration to gLite)  
production infrastructure

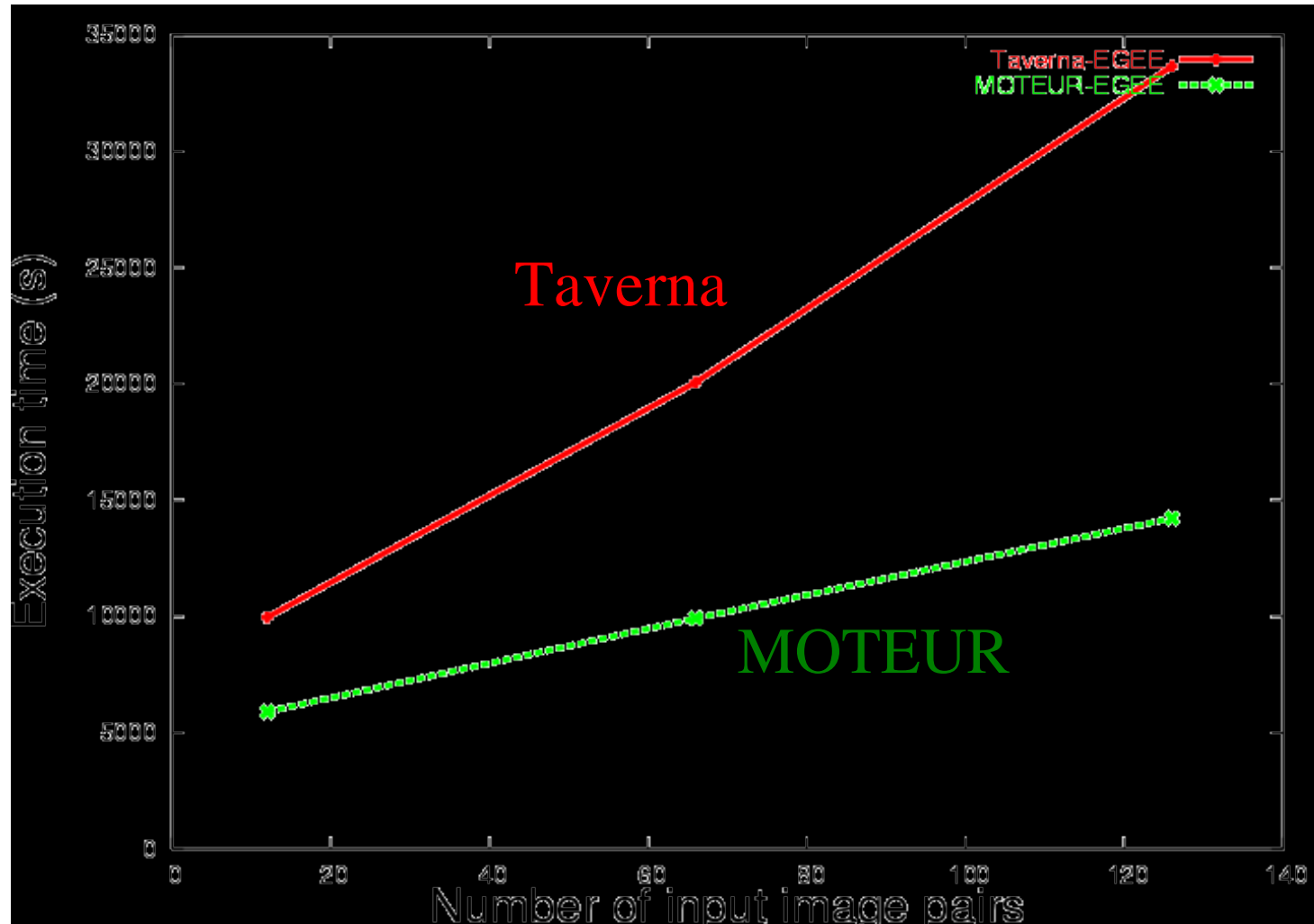

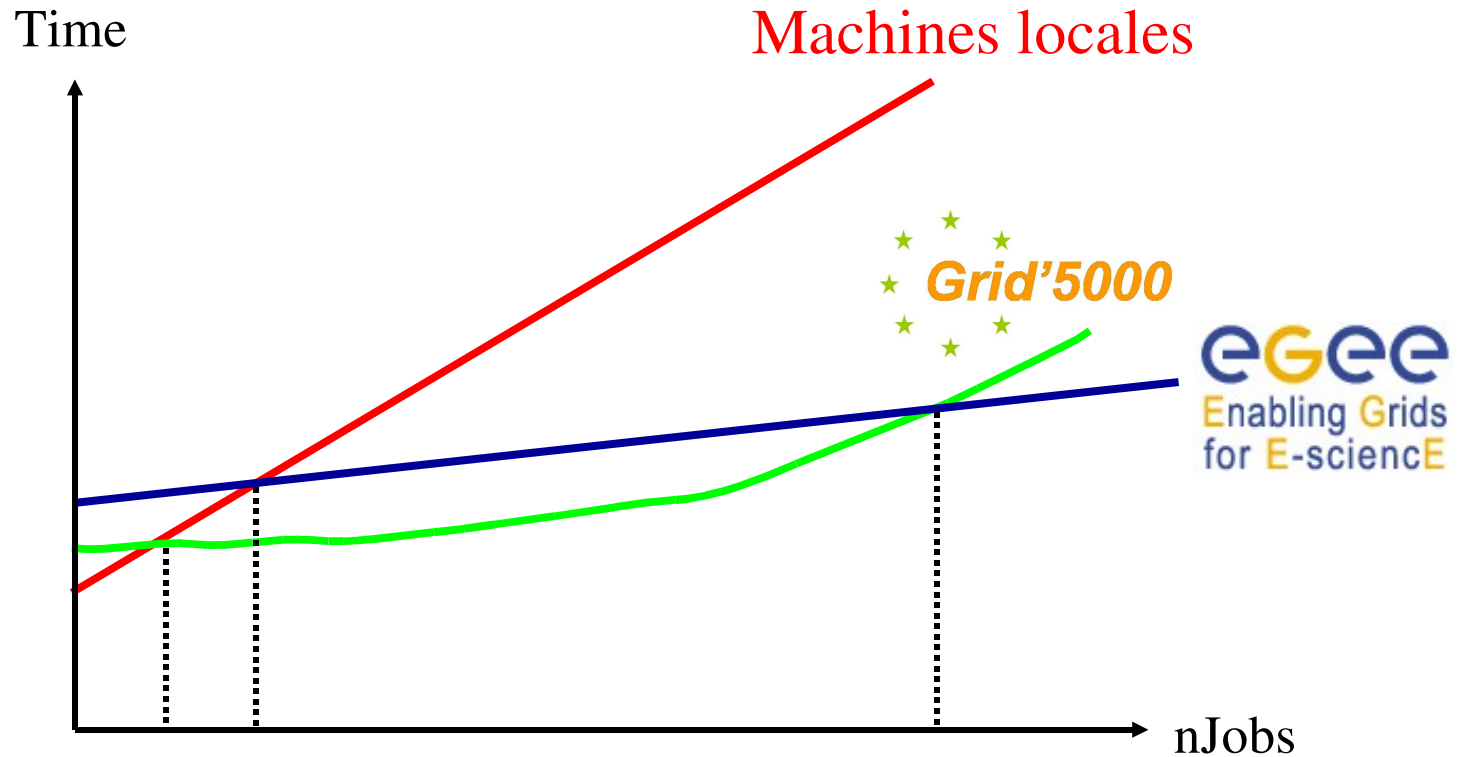

- **Monitoring processor performances**
- **Selecting infrastructure**

- $n$  jobs to be executed such that the total execution time is  $W$
- Optimal processing:  $n$  tasks executed in  $W/n$

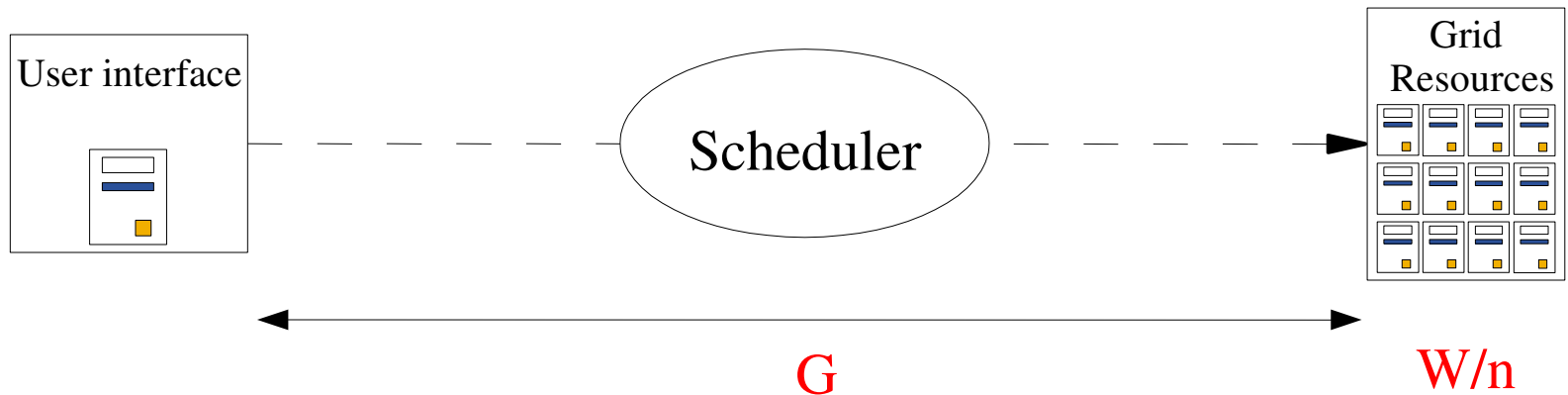

- Grid overhead: scheduling + queuing time  $G$
- Real execution time:  $H = \max(G + W/n)$
- Hypothesis :  $G$  is a random variable (of unknown distribution)

- Minimize H expectation

$$E_H(n) = \int_{\mathbf{R}} t.f_H(t)dt$$

$$F_H(t) = P(H < t) = \prod_{i=1}^n P\left(G + \frac{W}{n} < t\right) = P\left(G < t - \frac{W}{n}\right)^n = F_G\left(t - \frac{W}{n}\right)^n$$

$$f_H(t) = \frac{dF}{dt} = n.f_G\left(t - \frac{W}{n}\right).F_G\left(t - \frac{W}{n}\right)^{n-1}$$

$$E_H(n) = \int_{\mathbf{R}} n.t.f_G(t).F_G(t)^{n-1} dt + \frac{W}{n}$$

- Unknown distribution function for G, varying through time

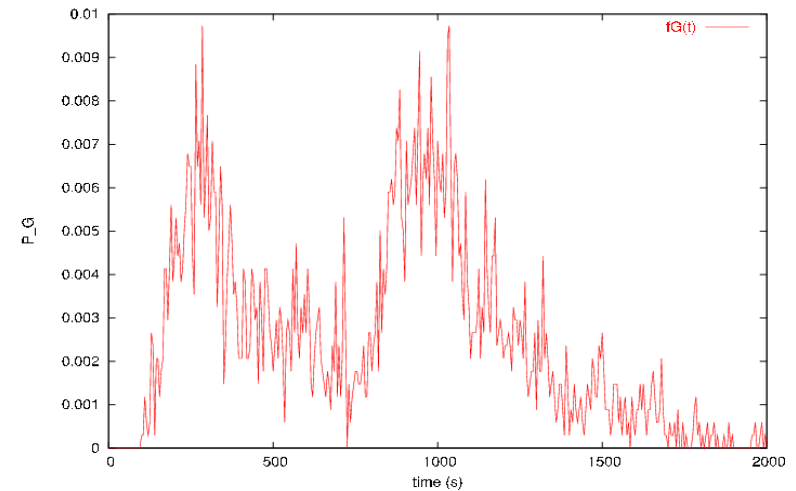
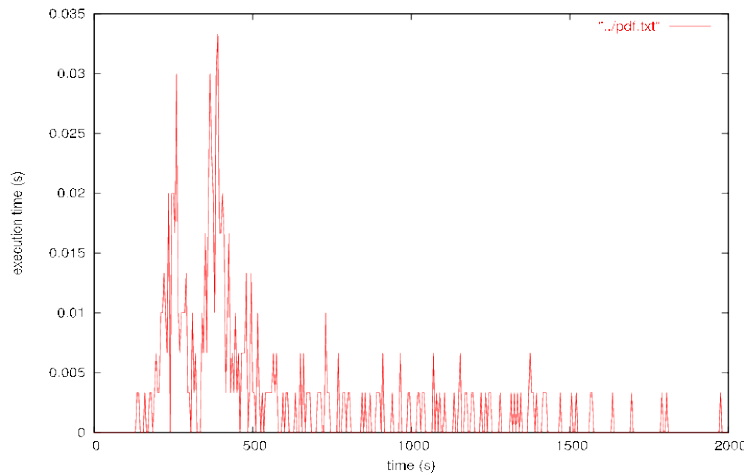

=> grid monitoring (test jobs submission)

- Preliminary results
  - 10% execution time by splitting W
  - 32% less jobs

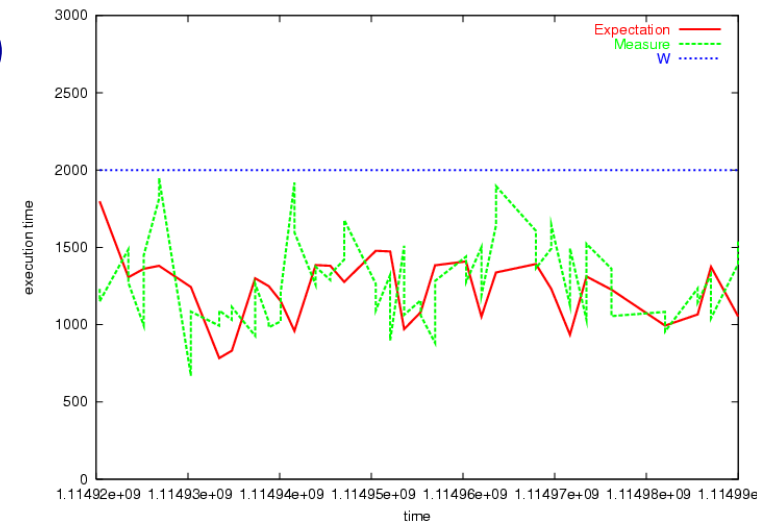

- **MOTEUR: optimized workflow enactor prototype**
  - Exploiting control and data parallelism
  - Data traceability
  - Generic workflow engine
- **On-going work**
  - Granularity of jobs (tasks splitting)
  - Data migration cost estimation
  - Multiple infrastructures usage
- **The Bronze standard application**
  - Application prototyped, production starting
  - Benchmark for
    - registration algorithms
    - Compression



- **Bronze Standard**

- Granger et al, MICCAI 2001 & ECCV 2002.
- Nicolau et al, IS4TM 2003.

- **Workflows on GRIDS**

- T. Glatard & al. Grid-enabled workflows for data intensive applications. IEEE Int. Symp. On Computer-based Medical Systems CBMS'05.
- T. Glatard & al. PDP'06
- T. Glatard & al. I3S Research Report, 2005,  
<http://www.i3s.unice.fr/~glatard/>



- **Robustness**
  - Local minima at a global scale

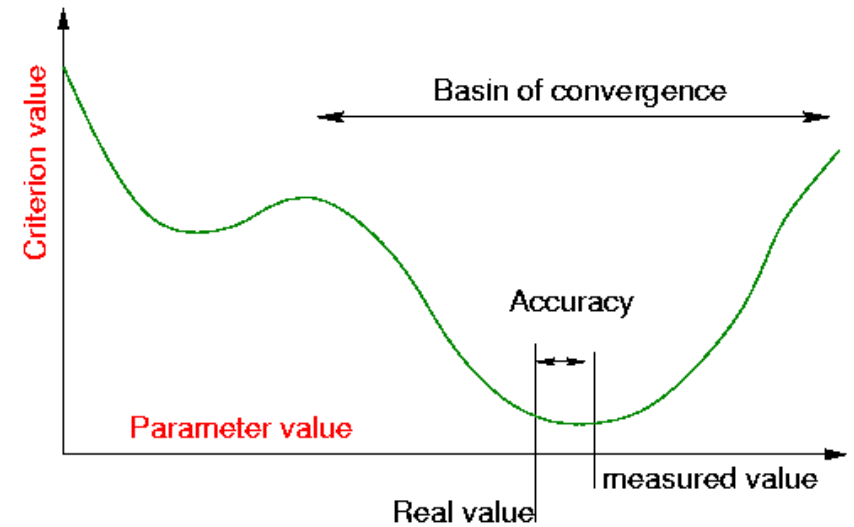

- **Uncertainty = deviation from the real transformation**
  - Bias (features, method, adequacy of the criterion)
  - Accuracy
    - Extrinsic (sensitivity to the noise on the features)
    - Intrinsic or precision (optimization, interpolation, local minima)

- User 1 (50 trials):
  - Repeatability:  
 $\sigma = 2.2$  mm
  - Bias: 3.0 mm
  - Accuracy:  
 $\sigma = 3.7$  mm

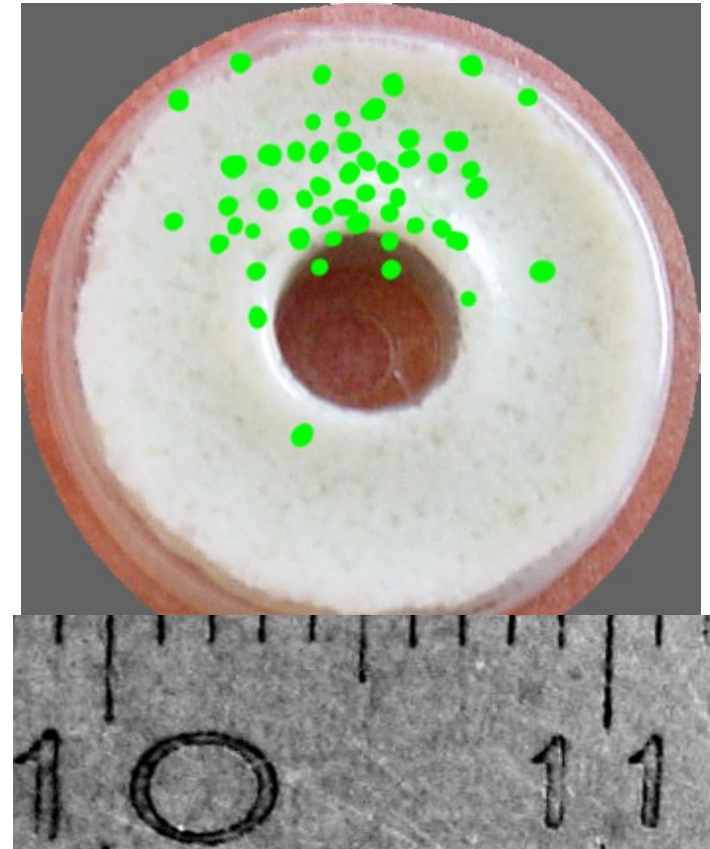

[ S. Nicolau, A. Garcia et al., Aug. & Virtual Reality Workshop, Geneva, 2003 ]

- User 2 (50 trials):
  - Repeatability:  
 $\sigma = 1.9 \text{ mm}$
  - Bias: 1.3 mm
  - Accuracy:  
 $\sigma = 2.3 \text{ mm}$

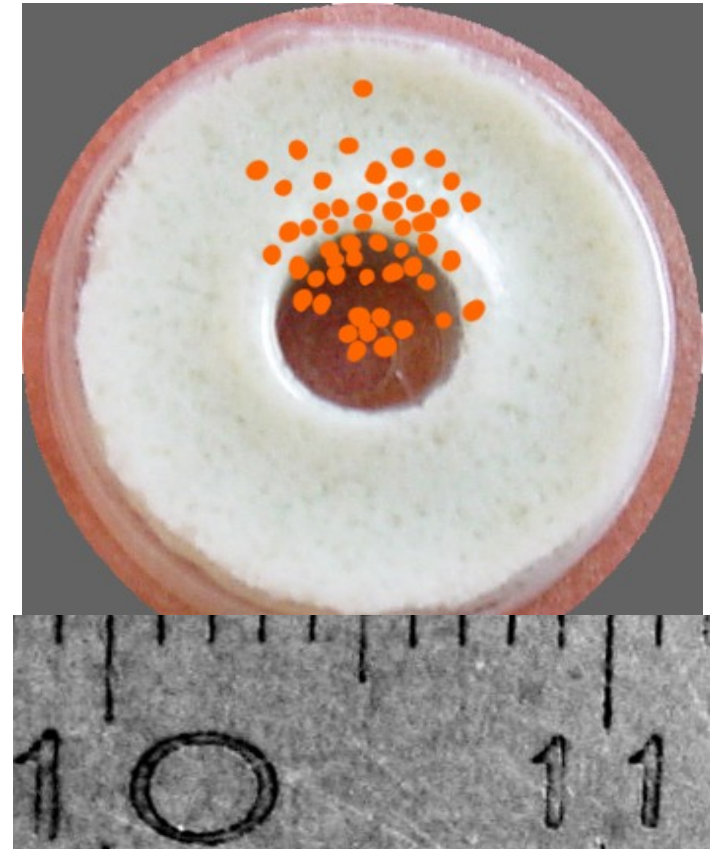

[ S. Nicolau, A. Garcia et al., Aug. & Virtual Reality Workshop, Geneva, 2003 ]

- Both users (100 trials):
  - Repeatability:  
 $\sigma = 2.2$  mm
  - Bias: 1.7 mm
  - Accuracy:  
 $\sigma = 2.8$  mm

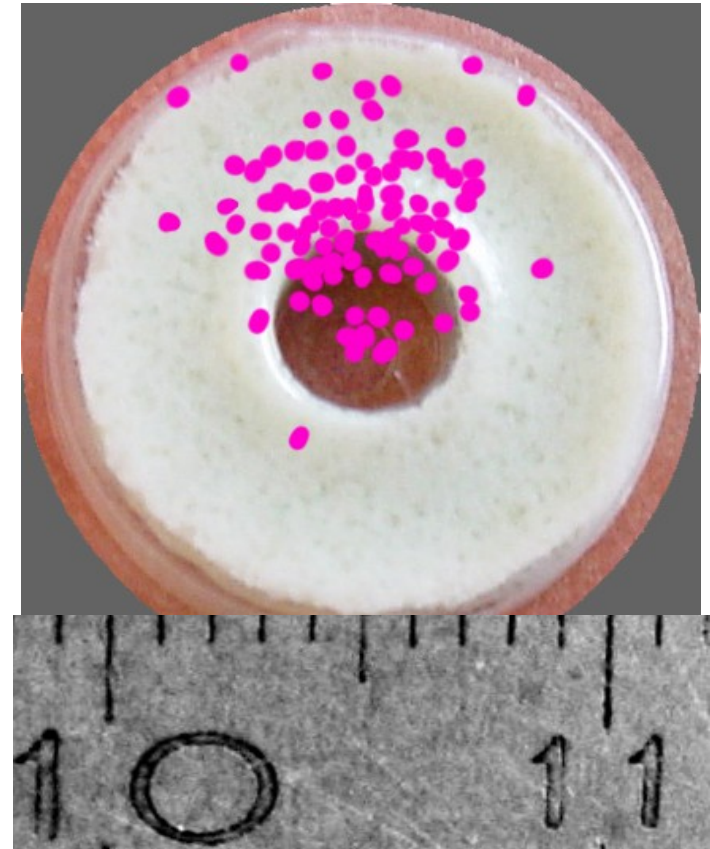

[ S. Nicolau, A. Garcia et al., Aug. & Virtual Reality Workshop, Geneva, 2003 ]

- **Registration or consistency loops**
  - Pennec et al. IJCV 25(3) 1997 & MICCAI 1998.
  - Holden et al. TMI 19(2), 2000
  - Roche et al MICCAI 2000 & TMI 20(10), 2001.
- **Cross-comparison of criterions**
  - Hellier et al MICCAI 2001 & TMI 22(9), 2003.
- **Ground truth as a hidden variable (EM like algorithms)**
  - Granger, MICCAI 2001 & ECCV 2002,
  - Warfield, MICCAI 2002, [Staple, segmentation]
  - Nicolau, IS4TM 2003
- **Error prediction**
  - Pennec et al. ICCV 1995, IJCV 25(3) 1997 & MICCAI 1998.
  - Fitzpatrick et al, MedIm 1998, TMI 17(5), 1999.
  - Nicolau et al, INRIA Research Report 4993, 2003

- Limitations of the data iteration strategy description**

- Scufi:

- dot and cross products operators

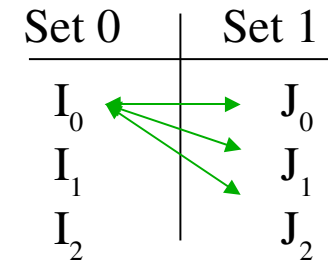
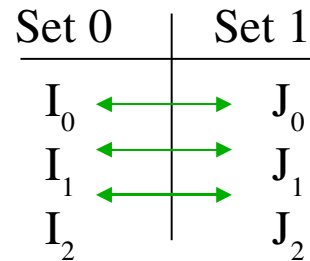

- In our case: register all images of

- the same patient
- the same modality
- A different exam date

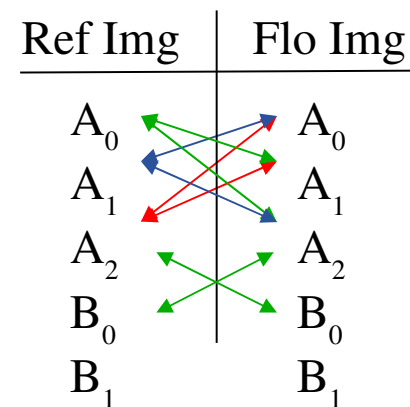



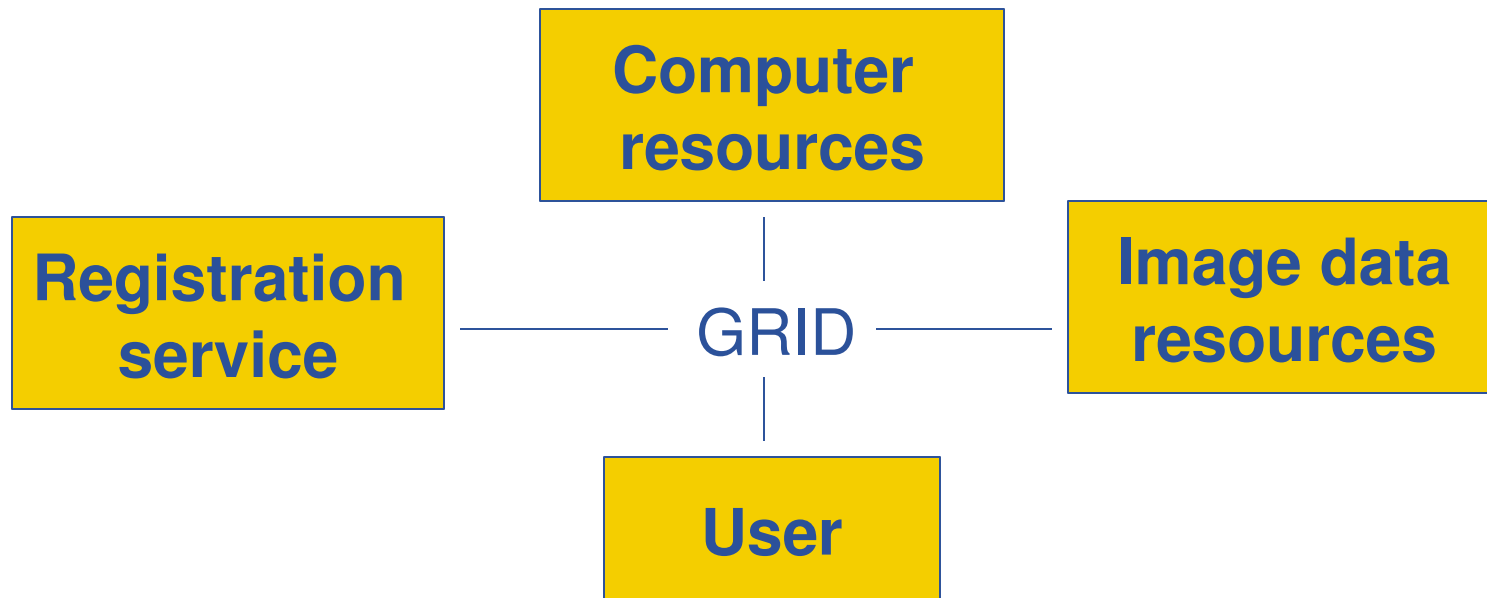

- **Scenario 1:**  
user accesses to registration services through the grid on his own data
- **Scenario 2:**  
the user test his algorithm on standard image databases

## Interoperability challenges

- **Image format (input / output)**
  - Dicom (communication module ?)
  - Basic 3D image format ?
- **Transformation formats**
  - Standardized displacement field / resampled image
  - Internal representation + std resampling function
- **Algorithm parameters / options**
  - Define std param. w.r.t. classes of registration problems
- **Interactivity**
  - State of advancement (reporting)
  - Interactive corrections

## Ontology of Algorithms (registration service)

- **Type of data**
  - Images (2D, 3D, time series)
  - Point clouds, landmarks
- **Type of spatial transformation**
  - Rigid / similarity / affine
  - Non rigid (global / local) (splines, def. Fields, polyrigids...)
- **From Data to Transformation**
  - Comparison metric (SSD, Correlation coefficient) takes into account the intensity transformation
  - Optimization procedure
  - Interactivity

## Ontology of Registration Problems (image databases)

- **Modality involved (specifies the type of data)**
  - Monomodal (CT, MR, US, Video, point measures...)
  - Multimodal (combination of above)
  - Atlas to modality
- **Image content (specifies the type of transformation)**
  - Anatomical part concerned (head, thorax, abdomen...)
  - Changes expected
    - *intrasubject / intersubject / atlas*
    - *Smooth evolution / pathology*

- **Description du Workflow**
  - Expose Tristan
- **Image database standardization**
  - Geometrie des images (dicom -> simple 3D format)
  - Que faire avec des images tiltees ?
  - Format des images (pour l'instant inr)
- **Registration algorithm standardization**
  - Format des transformations: gerer les multiples conversions
  - Description du parametrage des algorithmes pour des types de recalage donnees, eg: MR T1, T1i, T2, PD, Flair

- **Probleme medical**
  - Organe / pathologie
  - Probleme de recalage (e.g fusion pour planning oncologie)
- **Base de donnee image**
  - 2 types d'images (e.g. MR T1, T1i, T2, PD, Flair...)
  - Nb patients suffisant, Nb instant temporels >1 ?
- **Compression**
  - Nb parametres? Compression sur 1 ou les 2 images ?
  - PB de compression: optimale (stockage) / aleatoire (pertes reseau)
- **Recalage**
  - Influence de l'algorithme / influence des parametres
  - Resultat = transformation

- **Evaluation du Resultat:**
  - Erreur / resultat sans compresssion (ou ground truth?)
- **Synthese de la population erreur+parametres**
  - Resume (rigide): stddev rotation/translation, %outliers
  - 30 a 50 exp / parametre a tester
  - Combien de parametres
    - compression / image / recalage / ??
  - Echelle de mesure
    - Absolue
    - Relative (requiert la variabilite normale)
- **Quelle est la question scientifique?**
  - E.g.: l'influence de la compression est negligeeable / la variabilite normale

- **Temps de calcul des algorithmes de recalage dans le workflow des bronze standard :**

<i>Algorithm</i>	<i>Local execution (cluster of 4 PCs)</i>	<i>Execution on EGEE</i>	<i>Speed-up</i>
CrestLine (25 crest lines extractions)	6h15	49min	7.65
Baladin (75 registrations)	24h25	4h07	5.93
CrestMatch (25 registrations)	5h29	24min	13.7
PFMatchICP (50 registrations)	2h42	37min	4.38
PFRegister (50 registrations)	7min	23min	0.3
Yasmina (50 registrations)	16h11	1h41	9.6
Total execution time	24h25	4h07	5.93

- **Problème de la granularité des jobs soumis :**
  - soumettre un job introduit un surcoût (soumission, ordonnancement, ...)
  - les jobs de durée faible sont pénalisés



- **But :** optimiser le nombre  $n$  de jobs à soumettre pour exécuter une tâche de durée  $W$

- **Temps total d'exécution :**

$$H = \max(G + W/n)$$

- $G$  est une va dont la loi change au cours du temps
- Mesure de la densité de probabilité de  $G$  :

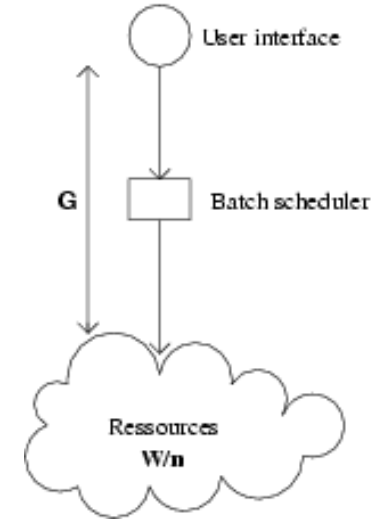

Soumission d'un job sur EGEE

